



# LESOTHO COMMUNICATIONS AUTHORITY

## APPLICATION FORM FOR NETWORK SERVICES

FORM 02

Physical Address: 30 Princess Margaret Road, Old Europa, Maseru Tel.: + 266 22224300/ 22326784  
Postal Address: LCA, P.O. Box 15896, Maseru 100. E-mail: [licensing@lca.org.ls](mailto:licensing@lca.org.ls)

**Note:** This form shall be completed by a person who has been duly authorized in writing to act as a representative of the Licensee<sup>1</sup>. Any information requested which does not fit in the form may be included in an appendix to this form. You are advised to fill in **all the information** to avoid delays in the processing of your application.

### 1. PARTICULARS OF AN APPLICANT

1.1	Full Name of applicant	Starlink Lesotho Pty Ltd		
1.2	Abbreviated Name			
1.3	Billing/Physical Address	22630 NE Marketplace Dr., Redmond, WA 98053		
1.4	Postal Address	22630 NE Marketplace Dr., Redmond, WA 98053		
1.5	Telephone Number	+1.310.363.6000		
1.6	e-mail	starlinkregulatory@spacex.com		
1.7	State legal form of applicant e.g. company, trust, other	Company		
<i>(Please attach a certified copy of company extracts, certificate of incorporation, constitution or founding document and certified passport copy of the director)</i>				
1.8	If registered, office of registration	Maseru, Lesotho		
1.9	Registration Number	89154		
1.10	Date of registration	17 April 2024		

### 2. APPLICATION DETAILS

2.1	Purpose for which the proposed communication is required	Satellite internet services for residents and businesses in Lesotho.		
2.2	(Please provide full details and network diagram as an attachment)	As presented in the attachment Technical Information/Annex 2		
2.3	Is spectrum or numbering resource required <sup>2</sup>	YES	<input checked="" type="checkbox"/>	NO

### 3. ACKNOWLEDGEMENT

3.1 The applicant acknowledges the statements in this form and accompanying documents are true and correct.

Signature Micaela Pawlak Date 01/24/2025

Full Name of Signatory Ms. Micaela Pawlak

<sup>1</sup> Attach certified ID/passport copy of the Director or authorized representative of the licensee.

<sup>2</sup> Attach a separate request for spectrum or numbering resources if there is a requirement.



LESOTHO COMMUNICATIONS AUTHORITY

Application form for Radio Links and Mobile Spectrum

Form 04

Physical Address: 30 Princess Margaret Road, Old Europa, Maseru Tel.: + 266 22224300/ 22326784  
 Postal Address: LCA, P.O. Box 15896, Maseru 100.  
 E-mail : [licensing@lca.org.ls](mailto:licensing@lca.org.ls)

**Note:** This form shall be completed by a person who has been duly authorized in writing to act as a representative of the Licensee<sup>1</sup>. Any information requested which does not fit in the form may be included in an appendix to this form. You are advised to fill in **all the information** to avoid delays in the processing of your application.

**1. PARTICULARS OF AN APPLICANT**

1.1	Full Name of applicant	Starlink Lesotho Pty Ltd
1.2	Physical Address	22630 NE Marketplace Dr., Redmond, WA 98053
1.3	Postal Address	22630 NE Marketplace Dr., Redmond, WA 98053
1.4	Telephone Number	+1.310.363.6000
1.5	e-mail	starlinkregulatory@spacex.com
1.6	State legal form of applicant e.g. company, trust, other	Starlink Lesotho (PTY) Ltd

*(Please attach a copy of certificate of incorporation, company extracts, or certified copy of constitution or founding document and certified passport copy of the director/applicant)*

1.7	If registered, office of registration	Maseru, Lesotho
1.8	Registration Number	89154
1.9	Date of registration	17 April 2024
1.10	Do you hold any other licence issued by the Authority?	N/A
1.11	If yes, what type of licence?	N/A
1.12	Licence Number and Date of issue	N/A

**2. SITE/STATION DETAILS**

2.1	Station Name	At the time of this application, there will be no Starlink ground station in Lesotho.					
2.2	Station Location	N/A					
2.3	Coordinates	Latitude	N/A		Longitude, E	N/A	
2.4	Elevation AMSL (m)	N/A					
2.5	Transportable	N/A	Radius if transportable (km)	N/A			
2.6	Building height (m)	N/A	Mast height (m)	N/A			
2.7	Noise environment	1. Low Noise	N/A	2. Medium Noise	N/A	3. High Degree of Noise	N/A

**3. EQUIPMENT INFORMATION**

3.1	Manufacturer	At the time of this application, there will be no Starlink ground station in Lesotho.					
3.2	Model	N/A					
3.3	Equipment Type:	1. Crystal <input type="checkbox"/> 2. Solid state <input type="checkbox"/> 3. Unknown <input type="checkbox"/> 4. PLL Control <input type="checkbox"/> 5. Synthesised <input type="checkbox"/>					
3.4	Frequency Range (MHz):	From	N/A	to	N/A		
3.5	TX/RX	1. Transmitter	N/A	2. Receiver	N/A	3. Both	N/A
3.6	Maximum Rated Power (W)	N/A					
3.7	Transmit Power (W)	N/A					
3.8	Serial Number	N/A					

**4. ANTENNA INFORMATION**

<sup>1</sup> Attach certified ID/passport copy of the Director or authorized representative of the licensee.

4.1	Manufacturer	SpaceX					
4.2	Model	UTA-22X					
4.3	Frequency Range (GHz):	From	R: 10.7 T: 14.0	To	R: 12.7 T: 14.5		
4.4	Polarisation	Receive (RHCP), Transmit (LHCP)					
4.5	Gain (dB)	TX	Max Slant: 32.2 dBi, Boresight: 37.2 dBi	RX	Max Slant: 31.5 dBi, Boresight: 35.8 dBi		
4.6	Antenna height above ground (m)	.26 m					
4.7	Directivity	1. Directional <input checked="" type="checkbox"/>			2. Omni-directional <input type="checkbox"/>		
4.8	Azimuth (degrees)	N/A					
4.9	Elevation (degrees)	N/A					
4.10	3dB Beam Width (degrees)	N/A					
4.11	ITU-R antenna reference	N/A					
4.12	<b>Equipment:</b> Please attach equipment technical data.						
4.13	<b>Antenna Pattern:</b> Please attach data page from manufacturer, or provide table of attenuation, in dB, against angle, or provide <b>calibrated</b> pattern diagram.						
<b>5. COVERAGE\LINK (Please fill in one of 5.1, 5.2, and 5.3 below as appropriate)</b>							
5.1	<b>Coverage Area (For Single Station System, e.g. Broadcast Station, GSM BTS)</b>						
5.1.1	Location (e.g. village)	Starlink terminals can be located anywhere in Lesotho.					
5.1.2	Coverage Radius	Nationwide					
5.1.3	<b>Please include a diagram to illustrate the area proposed for coverage</b>						
5.2	<b>Station to Station Link (e.g. microwave links)</b>						
5.2.1	Linked to Station (name)	N/A					
5.2.3	Coordinates	Latitude, S	N/A		Longitude, E	N/A	
5.2.4	Elevation AMSL (m)	N/A					
5.2.5	Building Height (m)	N/A		Mast Height (m)	N/A		
5.2.6	Equipment & Antenna Details	In case these are different from those in 4. & 5., please attach a sheet that describes each element as in 4.(4.1 to 4.8) & 5.(5.1 to 5.12) above.					
5.3	<b>Link to Geographic Point</b>						
5.3.1	Location	N/A					
5.3.2	Coordinates	Latitude, S	N/A		Longitude, E	N/A	
<b>6. FREQUENCY ASSIGNMENT</b>							
6.1	Requested frequency Range (GHz)	R: 10.7 T: 14.0	to	R: 12.7 T: 14.5			
6.2	Necessary Bandwidth (GHz)	2.5 GHz on a shared basis					
6.3	Emission Class (use the characters in Annex 1 to describe your signal)	N/A					
6.4	TX/RX	1. Transmitter		2. Receiver		3. Both	<input checked="" type="checkbox"/>
6.5	Preferred Frequency (MHz)	N/A					
6.6	Line Loss (dB)	N/A					
6.7	Minimum Receive Signal (dBW) (Protected Signal)	N/A					
<b>7. ACKNOWLEDGEMENT</b>							
7.1 The applicant acknowledges the statements in this form and accompanying are true and correct.							
Signature <u>Micaela Pawlak</u> Date: 1/24/2025							
Full names of signatory : Micaela Pawlak							
<b>For Office Use Only</b>							
Technical Data validated: <input type="checkbox"/> Name:.....Sign:.....Date:.....							

## Assigned Frequency (ies)

### ANNEX 1

#### First Character (Mandatory)

A	Double sideband.
B	Independent sidebands.
C	Vestigial sideband.
D	Emission in which the main carrier is amplitude and angle modulated either simultaneously or in a pre-established sequence.
F	Frequency modulation.
G	Phase modulation.
H	Single sideband, full carrier.
J	Single sideband, suppressed carrier.
K	Modulated in amplitude.
L	Modulated in width/duration.
M	Modulated in position/phase.
N	Emission of unmodulated carrier.
P	Sequence of unmodulated pulses.
Q	In which the carrier is angle modulated during the period of the pulse.
R	Single sideband, reduced or variable level carrier.
V	Which is a combination of the foregoing or is produced by other means.
W	Cases not covered above, in which an emission consists of the main carrier modulated, either simultaneously or in a pre-established sequence, in a combination of two or more of the following modes: amplitude, angle, pulse.
X	Cases not otherwise covered.

#### Second Character (Mandatory)

0	No modulating signal.
1	A single channel containing quantized or digital information without the use of a modulating sub-carrier. This excludes time-division multiplex.
2	A single channel containing quantized or digital information with the use of a modulating sub-carrier. This excludes time-division multiplex.
3	A single channel containing analogue information.
7	Two or more channels containing quantized or digital information.
8	Two or more channels containing analogue information.
9	Composite system with one or more channels containing analogue quantized or digital information, together with one or more channels containing analogue information.
X	Cases not otherwise covered.

#### Third Character (Mandatory)

A	Telegraphy for aural reception.
B	Telegraphy for automatic reception.
C	Facsimile.
D	Data transmission, telemetry, telecommand.
E	Telephony (including sound broadcasting).
F	Television (video).
N	No information transmitted.
W	Combination of the above.
X	Cases not otherwise covered.

#### Fourth Character (Optional)

A	Two-condition code with elements of differing numbers and/or durations.
B	Two-condition code without elements of the same number and duration with error-correction.
C	Two-condition code with elements of the same number and duration with error-correction.
D	Four-condition code in which each condition represents a signal element (of one or more bits).
E	Multi-condition code in which each condition represents a signal element (of one or more bits).
F	Multi-condition code in which each condition or combination of conditions represents a character.
G	Sound of broadcasting quality (monophonic).
H	Sound of broadcasting quality (stereophonic or quadrophonic).
J	Sound of commercial quality (excluding categories given in K and L below).
K	Sound of commercial quality with the use of frequency inversion or band-splitting.
L	Sound of commercial quality with separate frequency-modulated signals to control the level of demodulated signal.
M	Monochrome television (video only).
N	Colour television (video only).
W	Combination of the above.

X	Cases not otherwise covered.
---	------------------------------

***Fifth Character (Optional)***

N	No multiplexing employed.
C	Code division multiplex. (This includes bandwidth expansion techniques).
F	Frequency-division multiplex.
T	Time-division multiplex.
W	Combination of frequency-division multiplex and time-division multiplex.
X	Other types of multiplexing.

*Source: Ofcom, OfW84 – Guide to class of emission*

# STARLINK

## COMPANY INFORMATION

### Corporate Name

Starlink Lesotho (Pty) Ltd

**Unique Identification Number** 89154

### Address

Maseru, Lesotho

### Company Purpose

- Provide telecommunication services, to both public and private end users, including but not limited to the following activities:
- Provide services to individual households, businesses, and governmental entities.
- Develop, test, and commercialize software and hardware devices (including routers, antenna, and user terminals) that allow access to the Internet via satellite.
- Render internet services via satellite and installation of terrestrial hardware and devices.
- Import and export, purchase, sell, install, and lease, repair, maintain, service, refurbish and store antenna, routers and user terminals and related electronic equipment.
- Purchase, sell, develop, manage, and lease real property, fixtures, and movable assets.
- Provide data transport and data center services.
- Render administrative, technical, financial, economic, or managerial services to other companies, persons and/or enterprises.
- Provide telecommunications carrier services.
- Provide value added services; and
- Perform, promote and execute all activities, present or future that directly and indirectly favor and facilitate the development of the above corporate purpose.

### Chief Accounting Officer / Local Counsel

Zurayda Mayet

# STARLINK

## EXECUTIVE SUMMARY

For over 20 years, Space Exploration Technologies Corp. ("SpaceX") has provided dependable and affordable launch services to space agencies, satellite manufacturers, and operators from around the world with our family of launch vehicles. SpaceX is leveraging its engineering expertise and manufacturing abilities, and launch capacity, to design, deploy and operate Starlink, a Low Earth Orbit (LEO) satellite communications constellation. The first prototype satellites were launched in 2018, and consumer beta service began in October 2020. Today, SpaceX is providing fast, reliable internet to more than 4 million users in more than 120 markets on all 7 continents.

Starlink provides fiber-like connectivity with speeds of 30-150 Mbps download and up to 20 Mbps upload. By operating in LEO – far closer to Earth than traditional satellite operators — Starlink can provide low latency connectivity, enabling video calls, streaming and other high data rate activities that historically have not been possible with satellite internet. The Starlink user terminal is designed for ease of installation and requires no maintenance. Many users can be online within minutes of unboxing. SpaceX provides Starlink services with complete and transparent pricing: no data caps, no long-term contracts, no early termination fees, no hidden fees, no installation fees, Wi-Fi included, and no cancellation charges.

With Starlink, SpaceX can provide connectivity that will help to meet Lesotho's connectivity goals, reduce the infrastructure investment required to connect every mile, and complement traditional internet service providers' service areas. At a Starlink user's location, the Starlink user terminal — a small, phased array antenna — connects with Starlink satellites to relay information to/from the customer. The Starlink satellites then connect to nearby Starlink gateways, which connect to the internet via fiber.

Around the globe, Starlink has enabled communities in need to gain access to education, health services, enable remote work, and provide critical communications support during natural disasters. With Starlink, rural and remote classrooms can reap the same educational benefits of those in urban area. Farmers can leverage data-driven approaches to agricultural production and fisherman can stay in contact with family back at port. When natural disasters strike, Starlink can be deployed rapidly to support emergency responders and enable communication for those impacted.

# STARLINK

## BACKGROUND

### PROFILE: SPACEX

SpaceX is a private American corporation headquartered in Brownsville, Texas. Since 2002, the company has singlehandedly revolutionized the launch industry and transformed access to space for private companies and governments alike. Today, the company boasts over 10,000 employees around the world and continues to drive rapid innovation in space technologies to democratize access to this final frontier.

More recently, SpaceX developed, designed, notified, and began launching a constellation of satellites to provide broadband internet connectivity to every square inch of our planet: Starlink. Originally authorized by the Federal Communications Commission in 2018, the constellation will boast over 11,000 satellites once completed. Since receiving this authorization, SpaceX has deployed over 7,000 of these satellites and is already providing reliable, low-latency, high-speed broadband services to multiple markets in Europe, the Americas, Africa, Asia, and Oceania. Many additional markets are targeted for service introduction in 2025 and the years to follow with the eventual goal of being present in every market where possible.

The non-geostationary orbit ("NGSO") constellation is comprised of in-house designed and built satellites operating in the Ka and Ku bands to provide high throughput capability to end users. Deployed across multiple orbital planes, these satellites fly in LEO and offer download speeds of 30-150 Mbps. Starlink can deliver this high-speed broadband internet connectivity directly to end-users around the world by way of its own user terminals (Ku band). These terminals consist of a phased array antenna that SpaceX has made available to the consumer at an accessible cost for the first time. Through continued manufacturing innovation and new product development, prices are expected to further decrease over the next few years. To connect the constellation to the internet, Starlink uses a network of Gateway Earth Stations (Ka band) that are placed around the globe. SpaceX is investing in hundreds of these Gateway Stations to ensure we can blanket the earth and support as many customers as possible.

Since its founding, SpaceX has repeatedly demonstrated it is capable of rapidly delivering innovative solutions, managing complex programs, and developing revolutionary manufacturing capabilities. SpaceX is now the largest satellite operator in the world, operating more satellites than all the other satellite operators combined.

## ABOUT STARLINK

### *Starlink - Overview*

Starlink primarily aims to service individual consumers and small businesses, particularly in areas where access to high-speed broadband has been unreliable, unavailable, or unaffordable. Starlink can also serve large enterprises and provide local, regional, and national government agencies with connectivity to support a wide range of initiatives. The business plan for Starlink mirrors SpaceX's successful approach to launch services, where the product and service was designed to serve multiple customer segments, such as domestic and commercial companies, civil space agencies, and other government customers. Designing these services from the beginning to serve multiple customer requirements simultaneously allowed the company to spread the significant nonrecurring investment and made the business more resilient to downturns and procurement cycles in individual market segments. Using this same approach with Starlink offers the same



# STARLINK

benefits to this line of business.

## *Starlink – Products and Services*

Starlink is a broadband internet service provided to its customers by way of its constellation of satellites. The company's current commercial offers are divided into three main categories

### Starlink Standard Service

Starlink standard service is expected to offer speeds in the home of 30-150 Mbps download and up to 20 Mbps upload.

### Starlink Priority Service

Starlink priority service is expected to offer speeds of 40-200 Mbps download and up to 25 Mbps upload.

### Starlink ESIM

Noting the need for good internet anywhere within Lesotho, SpaceX has also engineered Starlink kits for maritime and aeronautical use. Starlink will maintain all the same technical specifications as terrestrial Starlink, however feature different mounting equipment to accommodate performance on moving platforms. To enable these use cases, Starlink seeks to obtain authorization on board ships, boats, planes, trains, and vehicles to make connectivity truly possible from any location allowing for unparalleled connectivity.

## *Starlink – Social Initiatives*

As Starlink has started to roll out internationally, one of the amazing things to observe is the difference connectivity can make to those in need. Some examples of Starlink customers around the globe that are benefiting significantly from high speed, low latency connectivity is:

- **Remote Communities:** An isolated community accessible only by aircraft, Pikangikum is a First Nation in northwestern Ontario, Canada. Three-quarters of the 3,000 indigenous population is under 25 years old. Prior to Starlink, the entire community shared one stream of limited bandwidth. Starlink connectivity was installed on 15 institutional buildings and 45 homes in the community. The community is using Starlink to deliver online education, provide telehealth services, and provide connectivity to support and enable businesses in the community. Read more from [CBC News](#).

# STARLINK

- **Education:** In Sotomo Alto, Chile, the only access to the village of 20 families is by boat. Prior to Starlink they had voice-only cellular connectivity. With Starlink, students are now using tablets provided by the Chilean education ministry to access online learning materials, participate in virtual museum visits and interact with students at other schools via video calls. Read and see a picture essay from Reuters [here](#). Starlink is providing similar connectivity to school districts in Texas and Virginia in the United States.
- **Natural Disaster Response:** Starlink offers unprecedented connectivity continuity during cases of natural disaster.
  - When a devastating volcanic eruption and tsunami cut off parts of Tonga from communications, Starlink provided 50 user terminals to be distributed to connect remote villages in the outlying islands of Tonga.
  - Starlink was also deployed to areas of Germany impacted by severe flooding in July 2021. As a result of the flooding, cellular and internet service in the region was limited. Because Starlink was already licensed and operational in Germany when the flooding hit, we were able to work with local officials to deploy connectivity in a matter of days. This connectivity supported emergency responders conducting rescue operations and provided internet access to residents, allowing them to communicate with family and authorities. In addition to Germany, Starlink has provided similar support following wildfires in Washington State, United States and in the aftermath of Hurricane Ida in Louisiana, United States.

## CUSTOMER SERVICE

Starlink operates primarily as a Direct-to-Consumer product. This allows Starlink to keep costs as low as possible for customers. At the same time, Starlink builds networks of resellers and retailers that provide a tailored business model and in-person customer support in each market where we launch service. This approach allows customers to decide what kind of experience they'd like to have when purchasing Starlink, from completely remote, to fully hands-on.

Customers who purchase Starlink online will go to Starlink.com, enter their service address, and purchase the hardware and subscription online via credit card. Once the Starlink user terminal arrives to their address, customers then use the Starlink mobile application to install and start service in a matter of minutes. Should a customer need additional support, Starlink's mobile application allows customers to submit support tickets and exchange messages with our customer support team to quickly received the help they need. The Starlink support team provides 24/7 response support to customer inquiries via the [www.starlink.com](http://www.starlink.com) user account portal or through the Starlink mobile application in a variety of languages. This allows for a cohesive user experience and allows for support representatives to access all relevant technical information with minimal need to query the customer for any troubleshooting.

Customers who prefer an in-person experience when purchasing Starlink have the option to work with a Starlink reseller or retailer. Once Starlink launches in a market, we work to build a network of resellers and retailers who have the local knowledge and networks needed to adapt their

# STARLINK

business model to the needs of different communities.

- **Resellers** can sell hardware and set up kits for customers. They can also work with customer to accept cash or mobile money or even establish a payment plan. Resellers are also able to provide tailored customer support with their existing network of technical support teams.
- **Retailers** sell hardware to customers who can then use the Starlink mobile application to set up their account and start services. While resellers and retailers give Starlink customers options on how to purchase and receive support, all Starlink customers will have access customer support via the mobile applications if they choose.

The Starlink Kit will be free from defects in material and workmanship and meet the performance goals set forth in the Starlink Specifications. The Starlink Limited Warranty will be available for 12 months from the date of the original purchase on [www.starlink.com](http://www.starlink.com); or 12 months from the date purchased from an authorized retailer and operates alongside any rights customers may have under local consumer protection laws and in no way restricts those rights. Customers may return an undamaged, untampered and unmodified Starlink Kit and any accessories within 30 days of the Payment Due Date for a full refund.

## Network Configuration

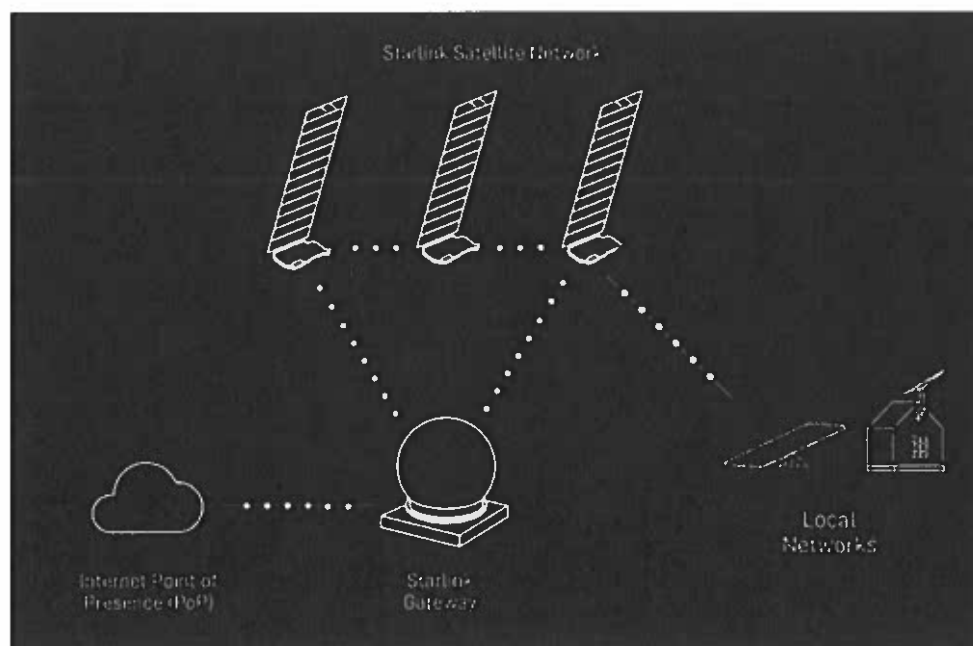

*Figure 1: The Starlink constellation relays information between a Starlink user terminal at a customer's location, Starlink satellites in space, and Starlink gateways that connect to the internet on the ground, eliminating the need to run fiber to each user. Starlink satellites operate much closer to Earth than traditional geostationary satellites, making it possible to provide our users high-speed and low-latency connectivity.*

# STARLINK

The Starlink constellation is comprised of more than 7,000 satellites deployed at an altitude of 550 kilometers from the earth's surface. This design ensures low latencies, high system capacity, and high network availability. Each satellite is fitted with multiple beams - forming Ka and Ku Band antennas that enable it to relay communications between user terminals and gateways on the surface of the planet.

As with all components of the Starlink system, these satellites are designed and manufactured by SpaceX. This in-house expertise allows the company to constantly innovate on the design efficiency of the satellites, enabling dynamic system improvements as the constellation is replenished over time.

Most importantly these satellites and the constellation's design exceed all international and domestic debris mitigation regulations, ensuring a safe and coordinated space environment for multiple operators and for many years to come.

The network architecture for the Starlink system is shown in Figure 1 above. There are three key components which enables the global system: the User Terminals at each customer site, the satellites orbiting overhead, and the Gateway antennas stations which connect the satellites to the internet on the ground.

## Quality of Service

Customers can expect the following quality of service described for the Starlink products described below:

- **Starlink Standard Service:** Starlink standard service is expected to offer speeds in the home of 30-150 Mbps download and up to 20 Mbps upload.
- **Starlink Priority Service:** Starlink priority service is expected to offer speeds of 40-200 Mbps download and up to 25 Mbps upload.

SpaceX has invested significantly in designing Starlink so that it changes the way people perceive gaining access to broadband internet. From the time a customer orders Starlink to the time they are online, the operation has been designed to be seamless, simple, and self-explanatory. In the same way you can order a mobile phone off the internet and set it up yourself, Starlink can put the most advanced technology into the hands of the least technologically experienced consumers without complication.

**Fulfillment:** To join the Starlink network, customers can place orders directly via [www.starlink.com](http://www.starlink.com). Upon receipt of payment, Starlink kits are shipped directly from one of Starlink's forward stocking locations around the world via courier to the customer's shipping address. When the Starlink kit arrives at a customer's location it will include everything required to get online. This includes the Starlink User Terminal, an integrated Wi-Fi router & power supply, cables, and mounting tripod. To connect to the internet, the customer simply places the User Terminal in a location that has a clear view of the sky and plugs it in to a power source. The User Terminal will automatically align itself with the satellites passing overhead and, moments later, the customer is connected to the internet.

# STARLINK

**Support:** Once connected, SpaceX's Network Operations Center (NOC) and customer success teams are responsible for delivering consistent, reliable service and troubleshooting/resolving issues with user connections. The Starlink support team provides 24/7 response support to customer inquiries via the [www.starlink.com](http://www.starlink.com) user account portal or through the Starlink mobile application in a variety of languages. This allows for a cohesive user experience and allows for support representatives to access all relevant technical information with minimal need to query the customer for any troubleshooting. The customer success team is co-located with the design team to ensure a tight feedback loop and ability to quickly address any issues that arise.

**Resellers and Retailers:** Once service is launched, Starlink actively works to build networks of local resellers and retailers.

## Utilizing Resellers and Retailers

Customers who prefer an in-person experience when purchasing Starlink have the option to work with a Starlink reseller or retailer. Once Starlink launches in a market, we work to build a network of resellers and retailers who have the local knowledge and networks needed to adapt their business model to the needs of different communities.

**Resellers** can sell hardware and set up kits for customers. They can also work with customer to accept cash or mobile money or even establish a payment plan. Resellers are also able to provide tailored customer support with their existing network of technical support teams.

**Retailers** sell hardware to customers who can then use the Starlink mobile application to set up their account and start services. While resellers and retailers give Starlink customers options on how to purchase and receive support, all Starlink customers will have access customer support via the mobile applications if they choose.

## Business Plan

For over 20 years, SpaceX has provided dependable and affordable launch services to space agencies, satellite manufacturers, and operators from around the world with our family of launch vehicles. SpaceX is leveraging its engineering expertise and manufacturing abilities, and launch capacity, to design, deploy and operate Starlink, a LEO satellite communications constellation. The first prototype satellites were launched in 2018, and consumer beta service began in October 2020. Today, SpaceX is providing fast, reliable internet to more than 4 million users in more than 120 markets on all 7 continents.

The NGSO constellation is comprised of in-house designed and built satellites operating in the Ka and Ku bands to provide high throughput capability to end users. Deployed across multiple orbital planes, these satellites fly in LEO and offer download speeds of 30-150 Mbps. Starlink can deliver this high-speed broadband internet connectivity directly to end-users around the world by way of its own user terminals (Ku band). These terminals consist of a phased array antenna that SpaceX has made available to the consumer at an accessible cost for the first time. Through continued manufacturing innovation and new product development, prices are expected to further decrease over the next few years. To connect the constellation to the internet, Starlink uses a network of Gateway Earth Stations (Ka band) that are placed around the globe. SpaceX is investing in hundreds of these Gateway Stations to ensure we can blanket the earth and support

# STARLINK

as many customers as possible.

Since its founding, SpaceX has repeatedly demonstrated it is capable of rapidly delivering innovative solutions, managing complex programs, and developing revolutionary manufacturing capabilities. This capability is none more evident than in its development and activation of its Starlink system. SpaceX is now the largest satellite operator in the world, operating more satellites than all the other satellite operators combined.

By operating in LEO – far closer to Earth than traditional satellite operators — Starlink provide low latency connectivity, enabling video calls, streaming and other high data rate activities that historically have not been possible with satellite internet. The Starlink user terminal is designed for ease of installation and requires no maintenance. Many users can be online within minutes of unboxing. SpaceX provides Starlink services with complete and transparent pricing: no data caps, no long-term contracts, no early termination fees, no hidden fees, no installation fees, Wi-Fi included, and no cancellation charges.

With Starlink, SpaceX can provide connectivity that will help to meet Lesotho's connectivity goals, reduce the infrastructure investment required to connect every mile, and complement traditional internet service providers' service areas. At a Starlink user's location, the Starlink user terminal — a small, phased array antenna — connects with Starlink satellites to relay information to/from the customer. The Starlink satellites then connect to nearby Starlink gateways, which connect to the internet via fiber.

Around the globe, Starlink has enabled communities in need to gain access to education, health services, enable remote work, and provide critical communications support during natural disasters. With Starlink, rural and remote classrooms can reap the same educational benefits of those in urban area. Farmers can leverage data-driven approaches to agricultural production and fisherman can stay in contact with family back at port. When natural disasters strike, Starlink can be deployed rapidly to support emergency responders and enable communication for those impacted.

# STARLINK

## Management Structure

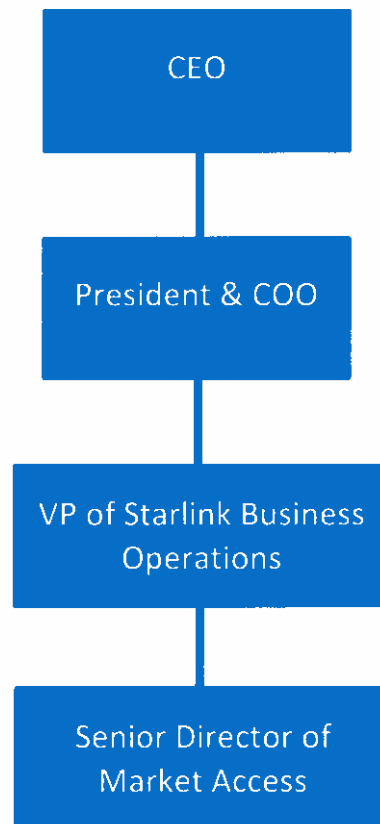

## Customer Service and Complaints Management Process

Starlink operates primarily as a Direct-to-Consumer product. This allows Starlink to keep costs as low as possible for customers. At the same time, Starlink builds networks of resellers and retailers that provide a tailored business model and in-person customer support in each market where we launch service. This approach allows customers to decide what kind of experience they'd like to have when purchasing Starlink, from complete remote, to fully hands-on.

Customers who purchase Starlink on-line will go to [Starlink.com](http://Starlink.com), enter their service address, and purchase the hardware and subscription on-line via credit card. Once the Starlink user terminal arrives to their address, customers then use the Starlink mobile application to install and start service in a matter of minutes. Should a customer need additional support, Starlink's mobile application allows customers to submit support tickets and exchange messages with our customer support team to quickly received the help they need.

The Starlink support team provides 24/7 response support to customer inquiries via the [www.starlink.com](http://www.starlink.com) user account portal or through the Starlink mobile application in a variety of languages. This allows for a cohesive user experience and allows for support representatives to access all relevant technical information with minimal need to query the customer for any troubleshooting. The customer success team is co-located with the

# STARLINK

design team to ensure a tight feedback loop and ability to quickly address any issues that arise.

Many customer questions are answered within our support topics, but if you cannot find the information you are looking for, or are still experiencing issues, the Starlink support team is staffed 24/7 in multiple languages to help. Customers can contact support by creating a support ticket describing your issue. Our support team will reply either via message or by calling the phone number on your account as soon as possible.

How to Create a Support Ticket:

- From the Starlink App: The app is the preferred method to contact support, as it sends along diagnostic information from your Starlink that enables faster resolution. Sign in to your account, click support option on the main screen, and then click the contact support button.
- From your Starlink.com account: Sign in to your Starlink account, navigate to the support tab, and then click contact support.

If needed, the customer support chatbot can help you create a support ticket. You can also create one directly by clicking "Do you need help from a human? Create a ticket" at the bottom customer support chatbot screen.

## Project Implementation Schedule

Service launch date depends on the date of license issuance. Pending the date of license issuance, service in Lesotho is tentatively planned to begin in mid-2025.

## Starlink Terms of Service

Starlink's Terms of Service can be found online at:

<https://www.starlink.com/legal/documents/DOC-1020-91087-64>





**KINGDOM OF LESOTHO**  
**THE COMPANIES ACT 2011**

## Company Extract

### General Details

Company Number:	89154
Company Name:	STARLINK LESOTHO (PTY) LTD
Company Status:	Active
Previous Statuses:	Awaiting LRA from 17-Apr-2024 to 19-Apr-2024
Incorporation Date:	17-Apr-2024
Company Type:	Private Company
Single or Multiple Shareholders:	Single
Does the company adopt its own articles?:	No
Share Capital:	1000
Annual Filing Month:	April
Annual Filing Day:	17
Business Activities:	4651 Wholesale of computers, computer peripheral equipment and software 4652 Wholesale of electronic and telecommunications equipment and parts 4741 Retail sale of computers, peripheral units, software and telecommunications equipment in specialized stores 6110 Wired telecommunications activities 6120 Wireless telecommunications activities 6130 Satellite telecommunications activities 6190 Other telecommunications activities 6311 Data processing, hosting and related activities 6312 Web portals

### Addresses

#### Registered Office Address

Physical Address: 20 Motsoene Road, Industrial Area, Maseru, Maseru, 100, Lesotho



**KINGDOM OF LESOTHO**  
**THE COMPANIES ACT 2011**

**Postal Address:** 20 Motsoene Road, Industrial Area, Maseru, 100, Lesotho

**Location of Company Registers**

**Physical Address:** 20 Motsoene Road, Industrial Area, Maseru, Maseru, 100, Lesotho

**Postal Address:** 20 Motsoene Road, Industrial Area, Maseru, 100, Lesotho

**Main Business Address**

**Physical Address:** 20 Motsoene Road, Industrial Area, Maseru, Maseru, 100, Lesotho

**Postal Address:** 20 Motsoene Road, Industrial Area, Maseru, 100, Lesotho

**Officers**

**Officer**

**Name:** Mrs Lauren Ashley DREYER  
**Position:** Director  
**Physical Address:** 1 Rocket Road, Mcgregor, Texas 76657, Texas, 76657, United States  
**Postal Address:** 1 Rocket Road, Mcgregor, Texas, 76657, United States  
**Nationality:** United States  
**Date of Appointment:** 17-Apr-2024

**Officer**

**Name:** Mr Richard Jinu LEE  
**Position:** Director  
**Physical Address:** 1 Rocket Road, Hawthorne, California 90250, California, 90250, United States  
**Postal Address:** 1rocket Road, Hawthorne, California, 90250, United States  
**Nationality:** United States  
**Date of Appointment:** 17-Apr-2024

**Shares & Shareholders**

**Total Shares:** 1000

**Do you have extensive shareholding?:** No

**Other Incorporated Entity Shareholder**

**Entity Name:** STARLINK HOLDINGS NETHERLANDS B.V



**KINGDOM OF LESOTHO**  
**THE COMPANIES ACT 2011**

Residential or Registered  
Office Address:

Pietersbergweg 283, 1105bm, Amsterdam, Netherlands

Postal Address:

Pietersbergweg 283, 1105bm, Amsterdam, 283, Netherlands

Appointed:

17-Apr-2024

## Share Allocations

### Allocation

Number of shares:

1000

Name:

STARLINK HOLDINGS NETHERLANDS B.V



**KINGDOM OF LESOTHO**  
THE COMPANIES ACT 2011

## **CERTIFICATE OF INCORPORATION**

Reg Number.                   **89154**  
TIN Number.                   **200153332-8**

I hereby certify that:

### **STARLINK LESOTHO (PTY) LTD**

was incorporated under the Companies Act 2011 as a private company on **17 April 2024** and that the liability of the shareholders thereof is limited.



**Registrar of Companies**

23 April 2024

The validation code for this certificate is LESOTHO-66823741. To check the validity of this certificate, go to <http://www.companies.org.ls/lesotho-companies-br/service/create.html?service=verifyDocumentCode> and enter the validation code.

The SpaceX logo, featuring the word "SPACEX" in a bold, sans-serif font with a stylized "X" that incorporates a rocket-like shape.

Space Exploration Technologies

April 18, 2024

Nizam Goolam, CEO  
Lesotho Communications Authority (LCA)  
30 Princess Margaret Road  
Maseru, Lesotho

Re: Economic Support for Starlink Lesotho (PTY) LTD

I, Richard Lee, in my capacity as Senior Director, Tax and Treasury of Space Exploration Technologies Corp ("SpaceX"), hereby certify that SpaceX intends to provide economic support to Starlink Lesotho (PTY) LTD once the entity has been established and while Starlink Lesotho (PTY) LTD demonstrates that it can become a profitable stand-alone entity.

Sincerely,

Richard Lee  
Senior Director, Tax and Treasury  
Space Exploration Technologies Corp

1 Rocket Road Hawthorne CA 90250

p 310.363.6000 f 310.363.6001

spacex.com



Dish

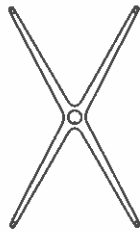

Base



Router

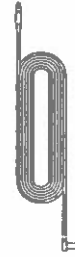

Starlink Cable  
22.9 m  
(75 ft)



AC Cable  
1.8 m  
(6 ft)

DISH

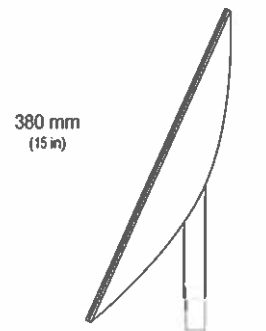
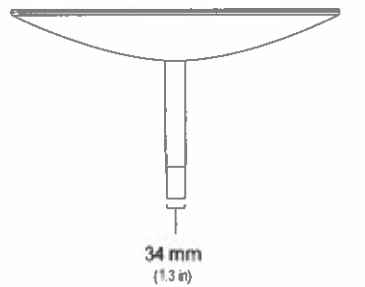
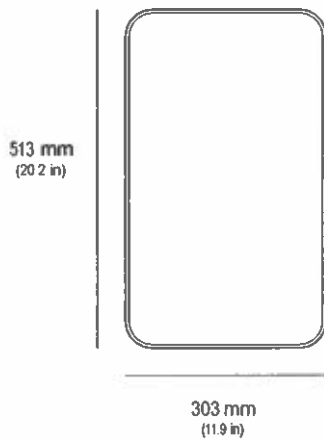

<b>Antenna</b>	Electronic Phased Array
<b>Field of View</b>	100°
<b>Orientation</b>	Motorized Self Orienting
<b>Dish Weight</b>	2.9 kg (6.4 lbs) without Cable 4.2 kg (9.3 lbs) with 22.9 m (75 ft) Cable
<b>Environmental Rating</b>	IP54
<b>Operating Temperature</b>	-30°C to 50°C (-22°F to 122°F)
<b>Wind Speed</b>	Operational: 80 kph+ (50 mph+)
<b>Snow Melt Capability</b>	Up to 40 mm / hour (1.5 in / hour)
<b>Power Consumption</b>	Average: 50-75 W

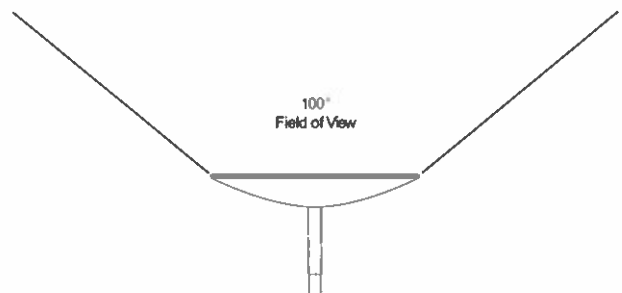

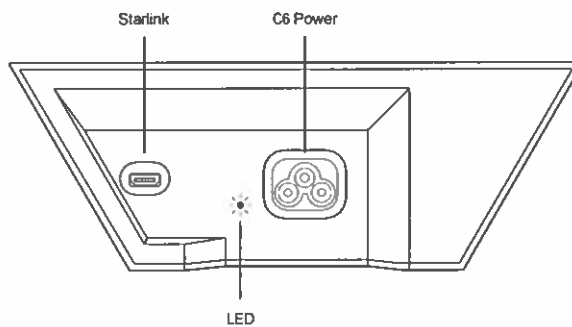
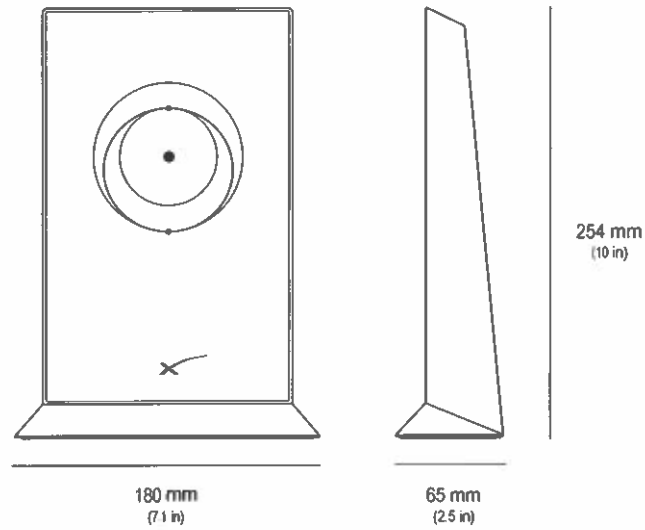

<b>Wi-Fi Technology</b>	802.11ac Dual Band
<b>Generation</b>	Wi-Fi 5
<b>Radio</b>	Dual Band -3 x 3 MIMO
<b>Operating Temperature</b>	-30°C to 50°C (-22°F to 122°F)
<b>Weight</b>	1 kg (2.2 lbs)
<b>Security</b>	WPA2
<b>Range</b>	Up to 185 m <sup>2</sup> (2000 ft <sup>2</sup> ) *Varies on placement, interference, and building materials
<b>Environmental Rating</b>	IP54 - Configured for Indoor Use
<b>Power Indicator</b>	White LED   Base of Router
<b>Mesh Compatibility</b>	Compatible with up to 12 Starlink Nodes
<b>Devices</b>	Connect up to 128 devices

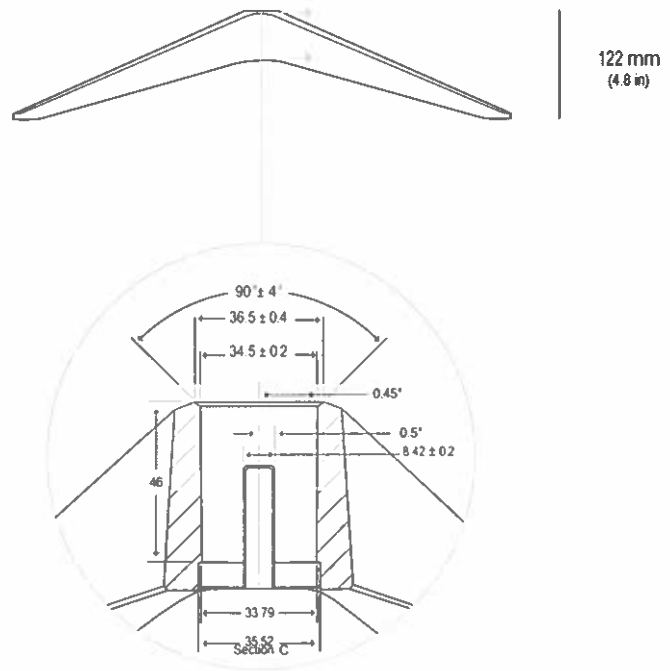
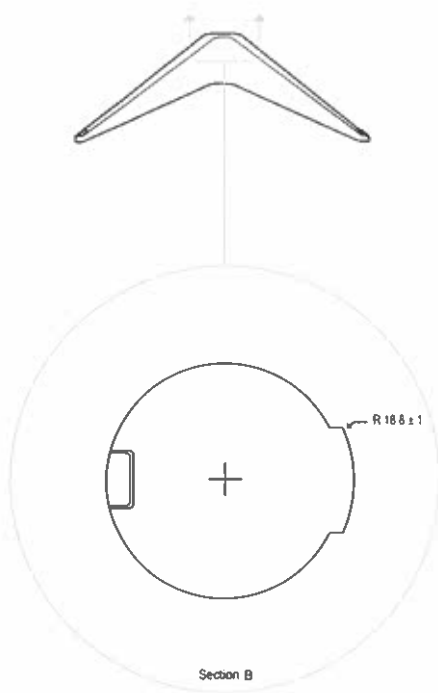
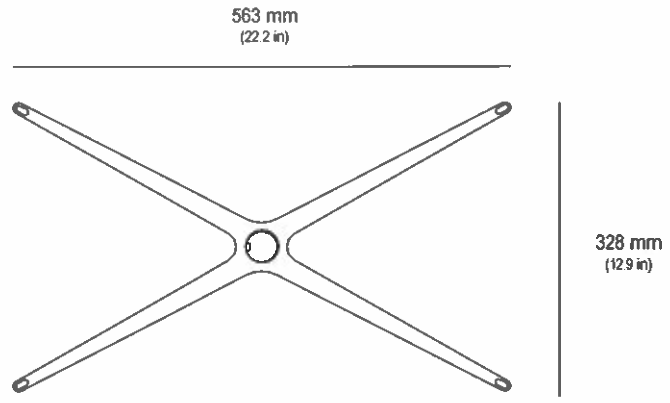
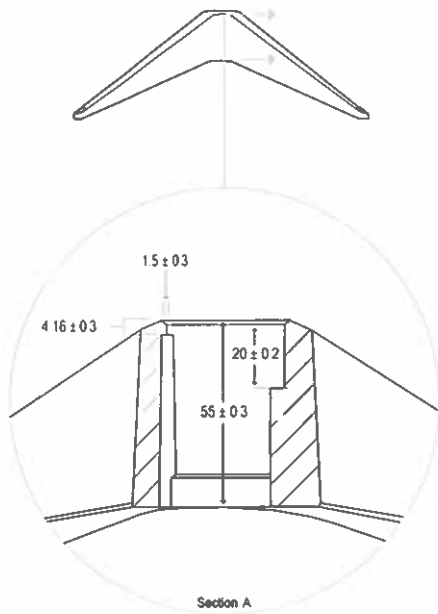



# STANDARD STARLINK CABLE

STARLINK

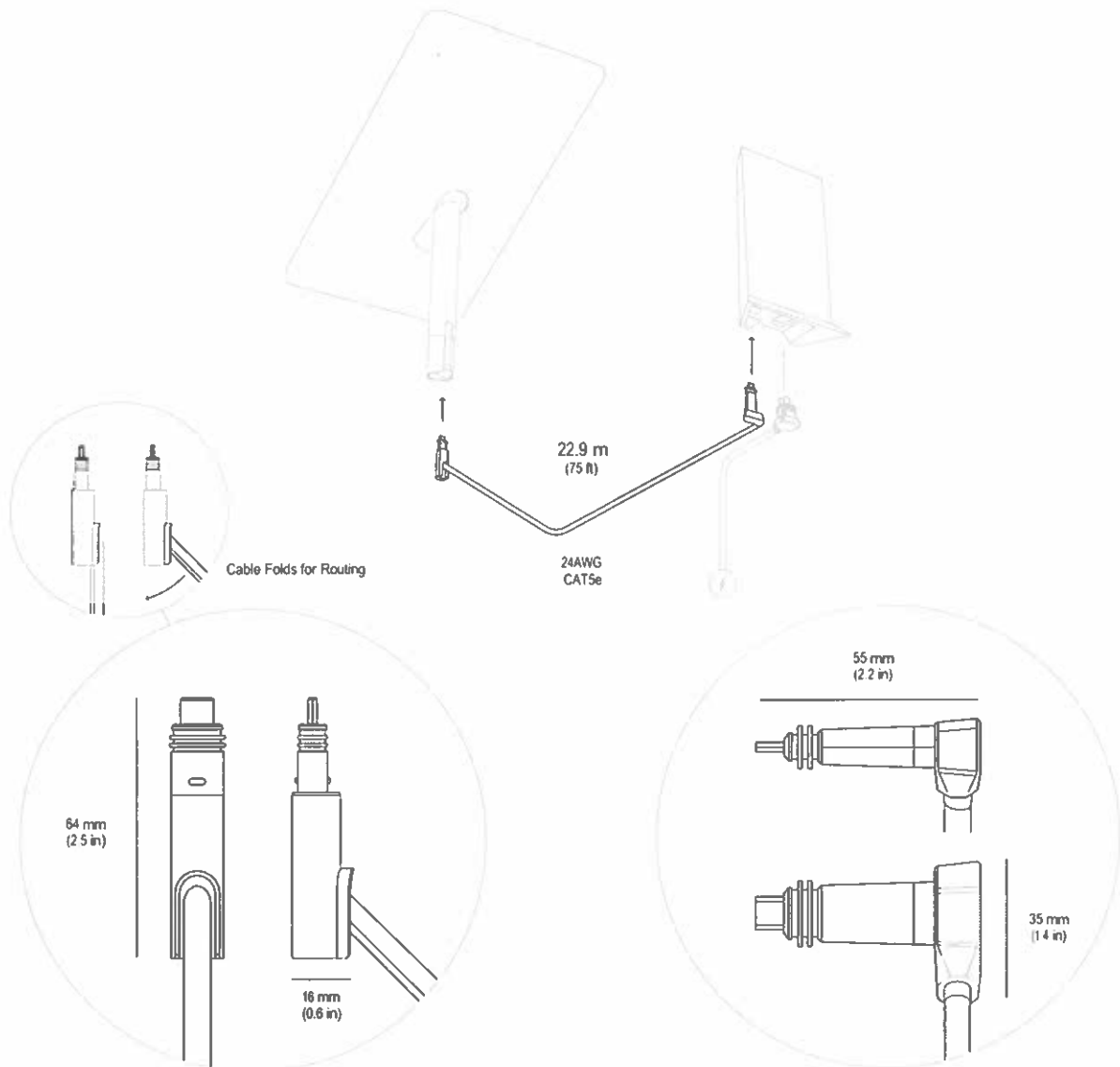

End	Pin	Ethernet Pin	Wire Color	Pin	End
Dish	A1, A2	B+	Orange White	A1, A2	Wi-Fi
	A3, A4	B-	Orange	A3, A4	
	A5, A6	A+	Green White	A5, A6	
	A7, A8	A-	Green	A7, A8	
	B1, B2	—	N / C	B1, B2	
	B3, B4	—	N / C	B3, B4	
	B5	D+	Brown White	B5	
	B6	D-	Brown	B6	
	B7	C-	Blue White	B7	
	B8	C+	Blue	B8	
	B9, B10	—	N / C	B9, B10	
	B11, B12	—	N / C	B11, B12	
	Shield Can	Drain Wire	Shell		

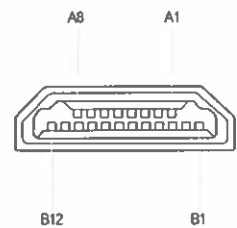

# STARLINK HIGH PERFORMANCE KIT

STARLINK

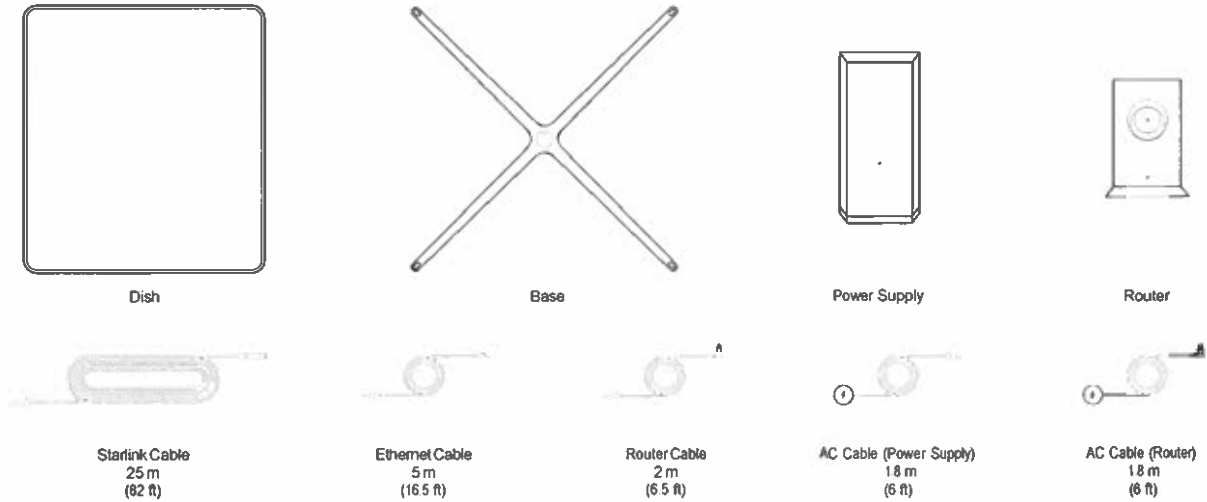

# STARLINK HIGH PERFORMANCE DISH

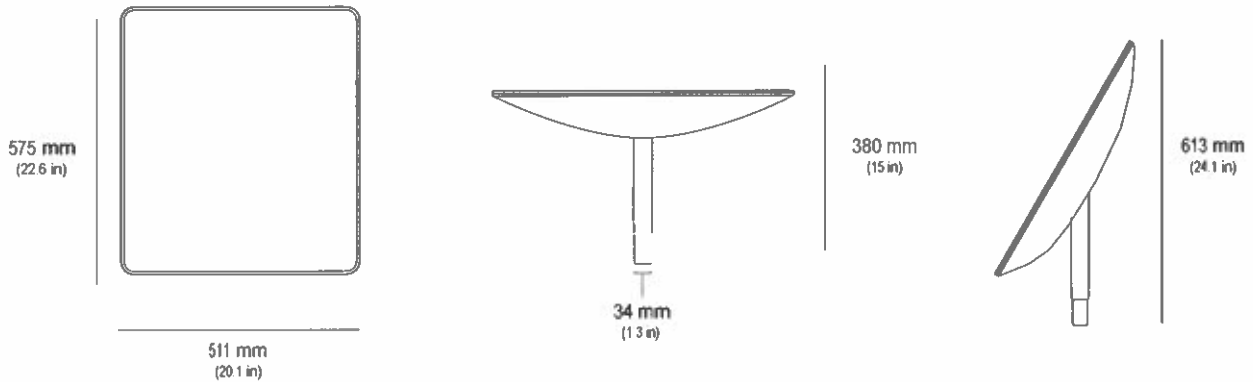

<b>Antenna</b>	Electronic Phased Array
<b>Field of View</b>	140°
<b>Orientation</b>	Motorized Self Orienting
<b>Dish Weight</b>	6.9 kg (15 lbs) without Cable 9.4 kg (21 lbs) with 25 m (82 ft) Cable
<b>Environmental Rating</b>	IP56
<b>Operating Temperature</b>	-30°C to 50°C (-22°F to 122°F)
<b>Wind Speed</b>	Operational: 80 kph+ (50 mph+)
<b>Snow Melt Capability</b>	Up to 75 mm / hour (3 in / hour)
<b>Power Consumption</b>	Average: 110-150 W
<b>Wi-Fi</b>	Dual Band Wi-Fi 5 - 3x3 MIMO
<b>User LAN</b>	

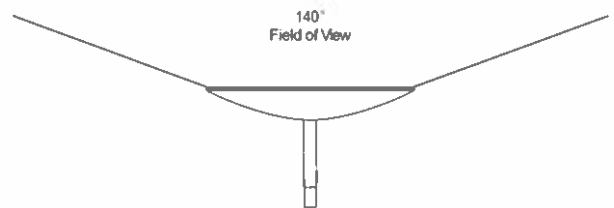

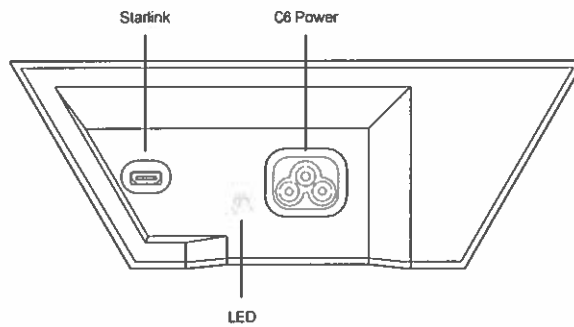
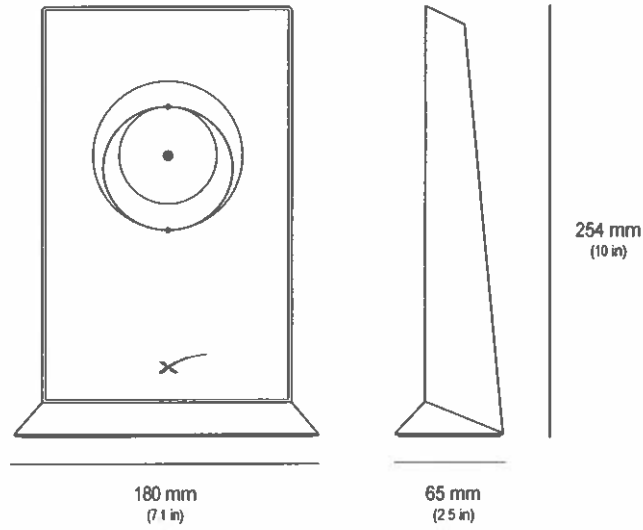

<b>Wi-Fi Technology</b>	802.11ac Dual Band
<b>Generation</b>	Wi-Fi 5
<b>Radio</b>	Dual Band -3 x 3 MIMO
<b>Operating Temperature</b>	-30°C to 50°C (-22°F to 122°F)
<b>Weight</b>	1 kg (2.2 lbs)
<b>Security</b>	WPA2
<b>Range</b>	Up to 185 m <sup>2</sup> (2000 ft <sup>2</sup> ) *Varies on placement, interference, and materials
<b>Environmental Rating</b>	IP54 - Configured for Indoor Use
<b>Power Indicator</b>	White LED   Base of Router
<b>Mesh Compatibility</b>	Compatible with up to 12 Starlink Nodes
<b>Devices</b>	Connect up to 128 devices

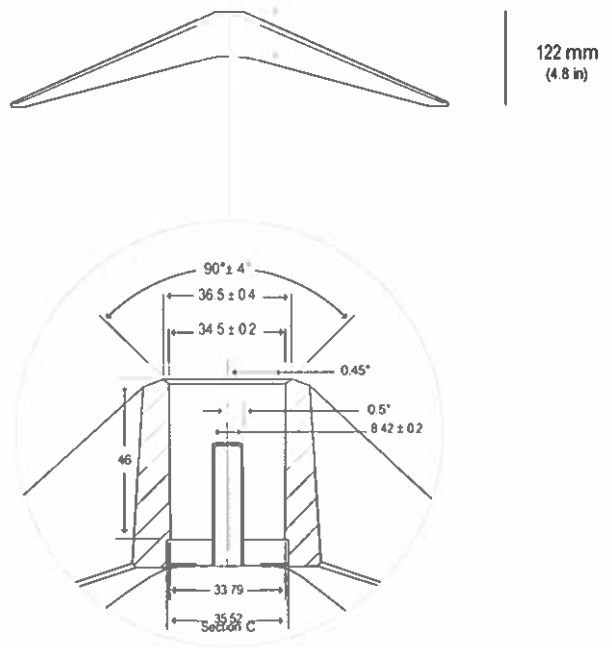
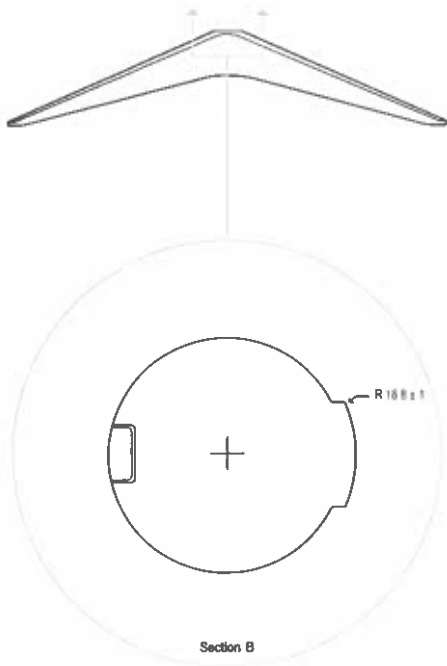
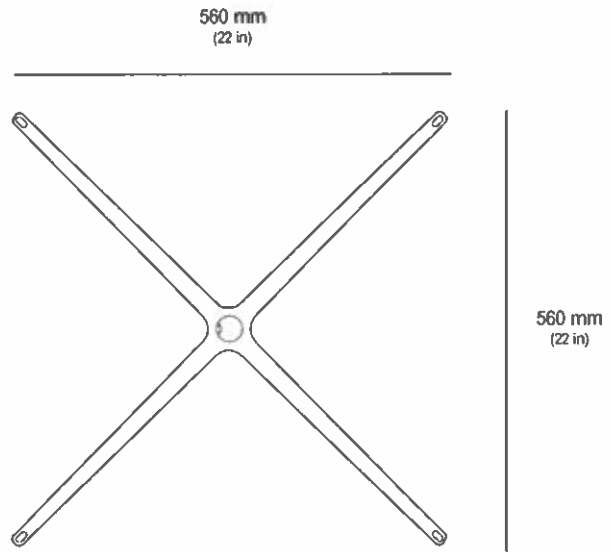
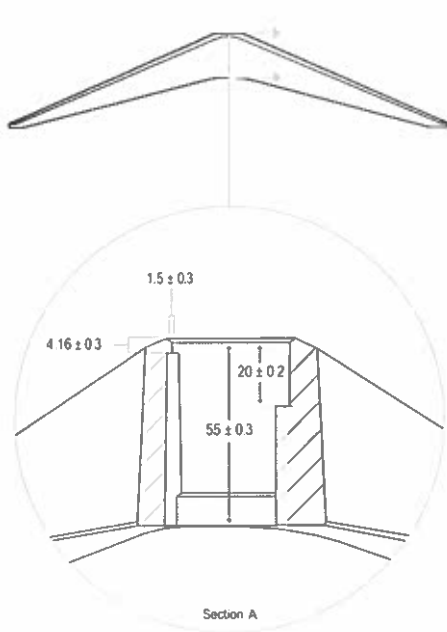

122 mm  
(4.8 in)

# POWER SUPPLY UNIT

STARLINK

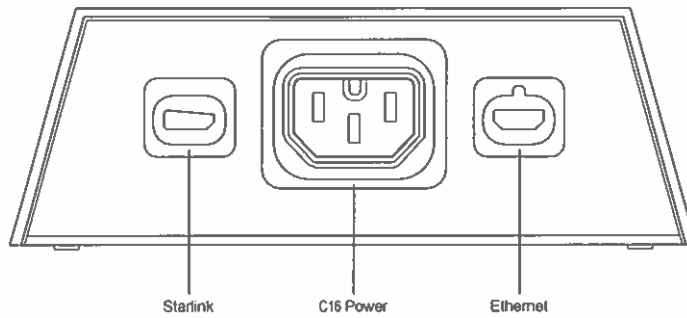
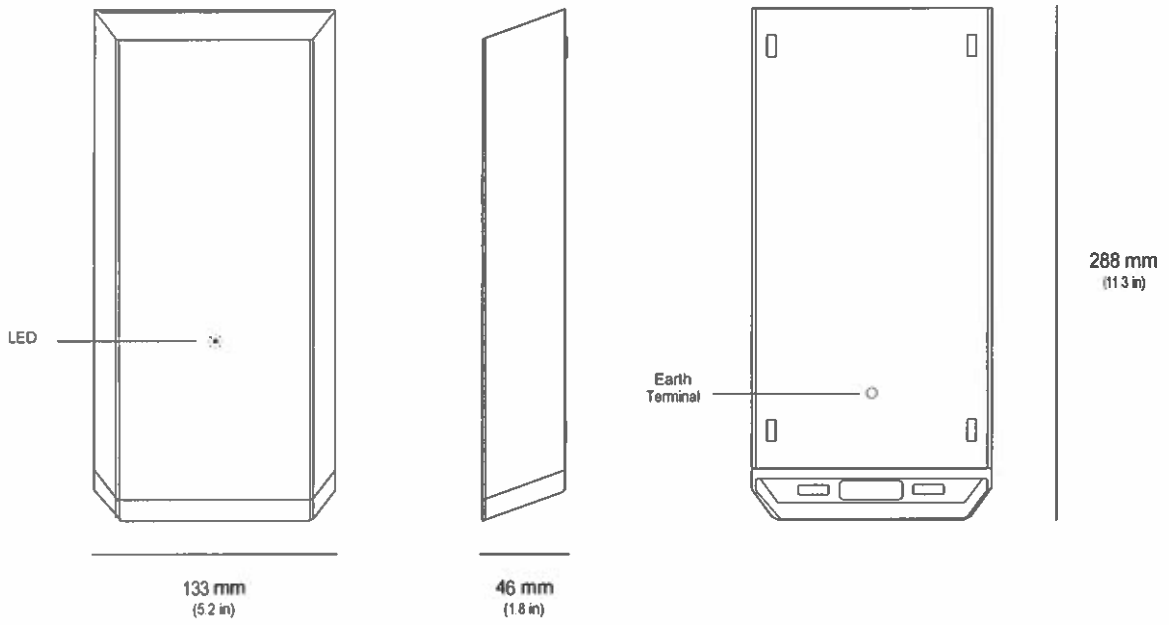

<b>Environmental Rating</b>	IP56
<b>Operating Temperature</b>	-30°C to 50°C (-22 to 122°F)
<b>Weight</b>	1.5kg (3lbs)
<b>Grounding</b>	Dedicated Earth Terminal
<b>Power Specifications</b>	100-240V - 6.3A 50 - 60 Hz
<b>Mounting</b>	Included Wall Mount

# HIGH PERFORMANCE STARLINK CABLE

STARLINK

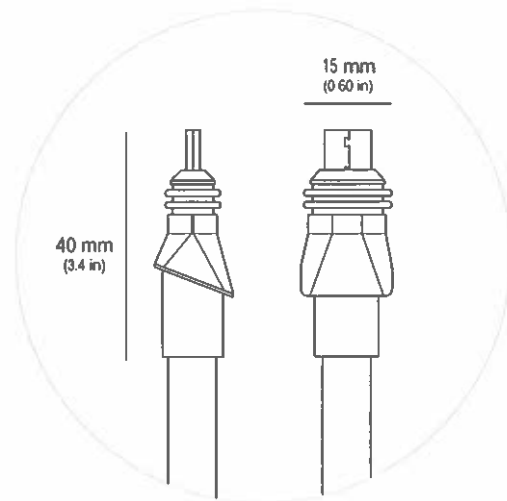
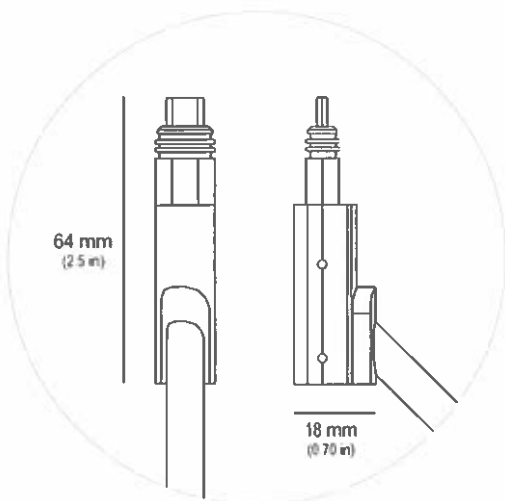
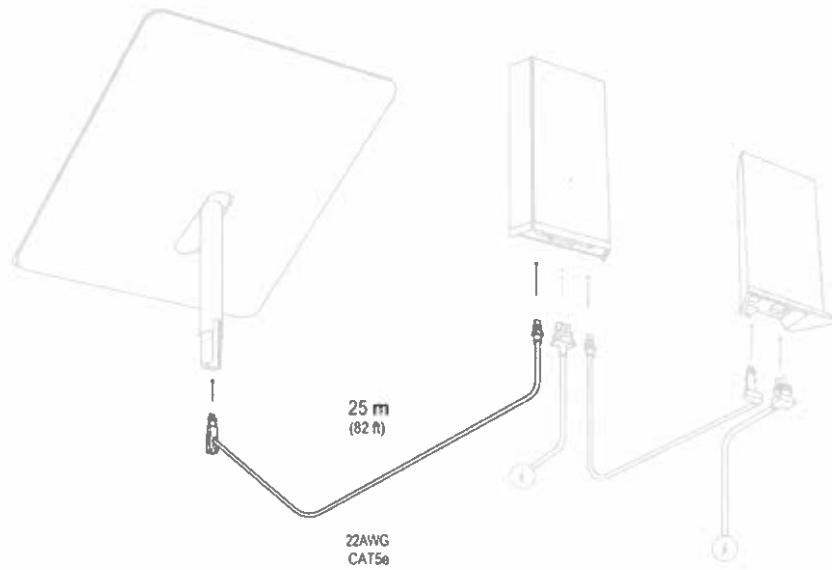

End	Pin	Wire Color	Pin	End
Dish	A1	Green	A1	Power Supply
	A2	Yellow	A2	
	A3	Blue	A3	
	A4	White	A4	
	B1	Orange	B1	
	B2	Purple	B2	
	B3	Brown	B3	
	B4	Gray	B4	
	B5	Shield / Shell	B5	

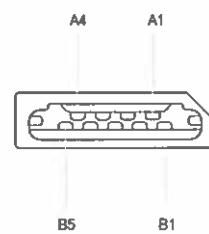

# HIGH PERFORMANCE ROUTER CABLE

STARLINK

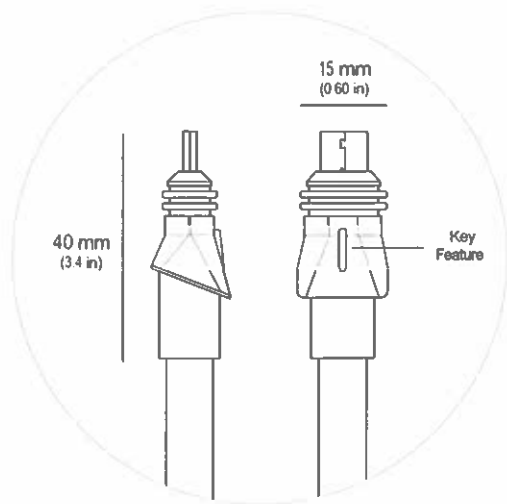
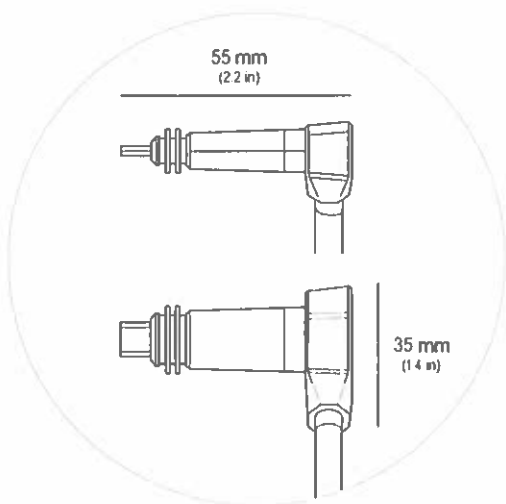
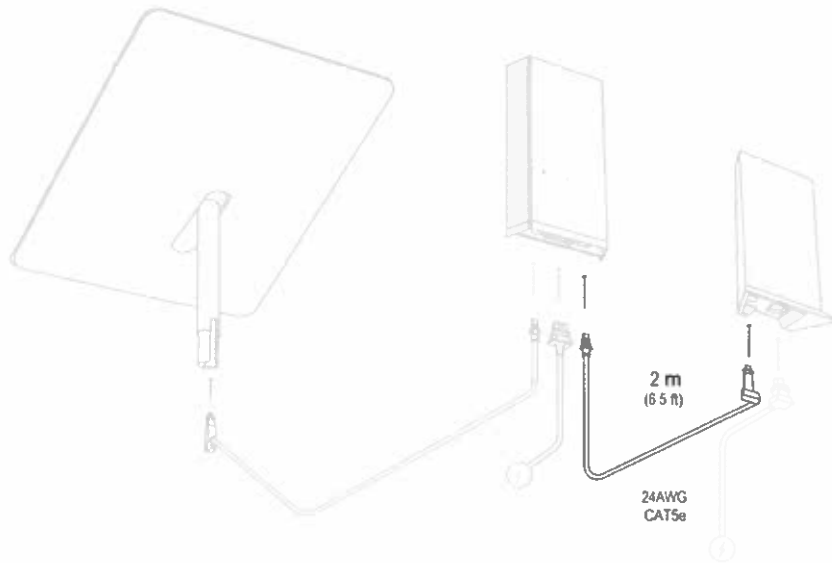

End	Pin	Ethernet Pin	Wire Color	Pin	End
Wi-Fi	A1, A2	B+	Orange White	A1, A2	Power Supply
	A3, A4	B-	Orange	A3, A4	
	A5, A6	A+	Green White	A5, A6	
	A7, A8	A-	Green	A7, A8	
	B1, B2	—	N / C	B1, B2	
	B3, B4	—	N / C	B3, B4	
	B5	D+	Brown White	B5	
	B6	D-	Brown	B6	
	B7	C-	Blue White	B7	
	B8	C+	Blue	B8	
	B9, B10	—	N / C	B9, B10	
	B11, B12	—	N / C	B11, B12	
	Shield Can	—	Drain Wire	Shell	

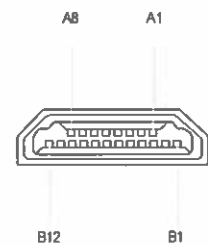

# HIGH PERFORMANCE ETHERNET CABLE

STARLINK

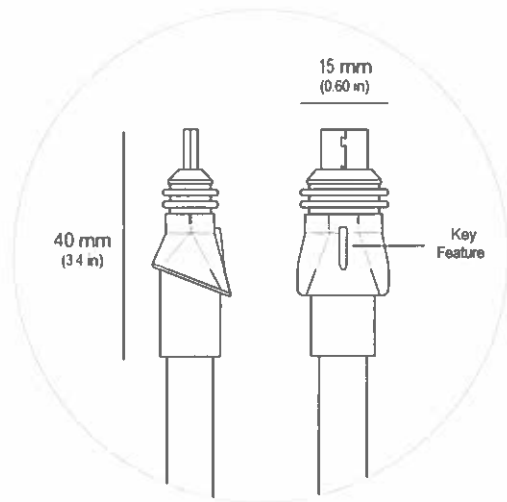
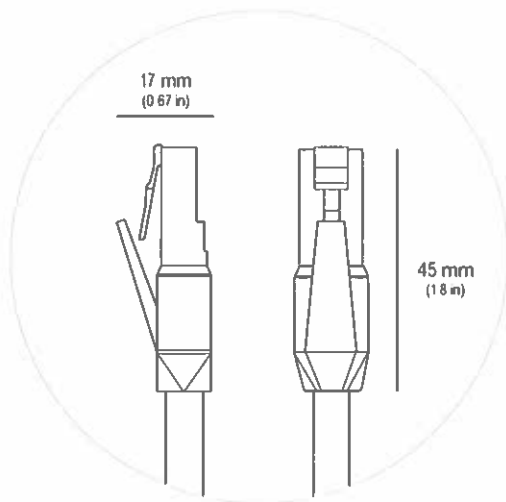
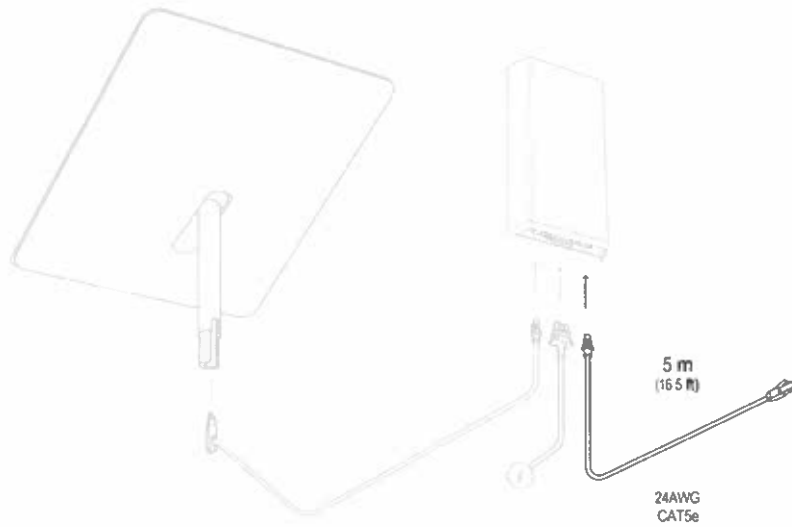

End	Pin	Ethernet Pin	Wire Color	Pin	End
RJ45	A1, A2	B+	Orange White	A1, A2	Power Supply
	A3, A4	B-	Orange	A3, A4	
	A5, A6	A+	Green White	A5, A6	
	A7, A8	A-	Green	A7, A8	
	B1, B2	--	N / C	B1, B2	
	B3, B4	--	N / C	B3, B4	
	B5	D+	Brown White	B5	
	B6	D-	Brown	B6	
	B7	C-	Blue White	B7	
	B8	C+	Blue	B8	
	B9, B10	--	N / C	B9, B10	
	B11, B12	--	N / C	B11, B12	
		Shield Can	Drain Wire	Shell	

